



## MAXI-HEAT®

The **Maxi-Heat®** line includes a robustly designed towable indirect fired heater, with 1M BTU. This Unit provides heat for different applications including severe harsh conditions. The 1M includes two independently operating burners providing up to a combined 1,000,000 BTUs of heat. For ease of operation the **Maxi-Heat®** comes fully equipped with the iQ system, which automatically calibrates each burner providing reliable trouble free operation, eliminating the tedious trial and error combustion measurements and adjustments. Recirculation is standard on all **Maxi-Heat®** products resulting in increased efficiency of the heater and less fuel consumed. The **Maxi-Heat®** can go from warming equipment to curing concrete, the heat you can rely on when you need it most.



## KEY FEATURES

# Allmand® MAXI-HEAT®

**External Control Panel** Provides the operator with the necessary operating parameters needed during operation eliminating the need to open the heater door.

**Flexible Applications** Twin Heater units on the 1M BTU model providing flexibility of heat needed for the jobsite.

**iQ System** Automatically calibrates burner for temperature, humidity and barometric pressure. Provides damper setting on color display, and information on efficiency, target and actual outlet temperatures.

**Lifting Eye**

**NEW**

**Remote Fuel Valve and Pump** can be optionally equipped to pump fuel to run the Maxi-Heat from a remote fuel tank.

**Reversible Coupler**  
Adjustable height 2" Bulldog and 3" pintle

**NEW**

**Pacbrake Shut-Off Valve** The optional air intake emergency shut-off valve automatically closes the valve and shuts down the engine when an overspeed runaway condition occurs.

**Centrifugal Fan** Provides decreased dBA output and increased air flow efficiency.

**Air Recirculation Inlet**  
Air inlet comes standard and results in increased efficiency of the heater and less fuel consumed.

**NEW**  
**Adjustable Air Recirculation Inlet** The optional adjustable air recirculation inlet connection changes size to fit either 16" or 20" ducting.

**Durable Steel Enclosure** is built to last through the toughest environments and conditions.

**Sleek Design** allowing for ease of transport and maneuverability.

**NEW**  
**CSA Approved Steel Fuel Tank** The optional 175 gallon steel double wall (UN-31A rated) fuel tank meets CSA standards.

**16", 12" or 20" Duct Flange Outlets**

**Fluid Containment System (FCS)** Provides 130%+ fluid containment for all on-board fluids.

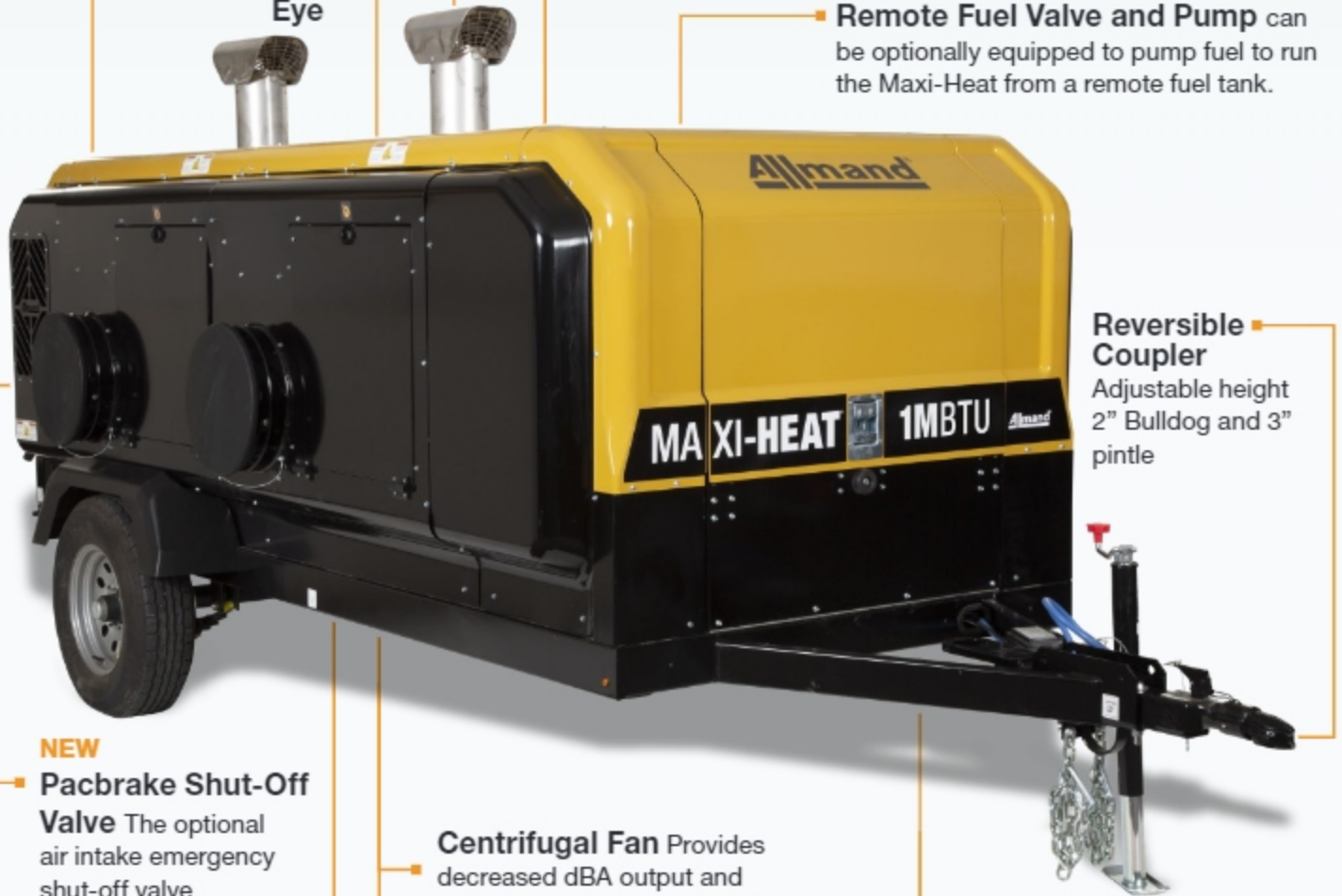

Model	Maxi-Heat® 1MBTU	Maxi-Heat® 1MBTU
Engine Brand	Kubota D1005	CAT C1.1
Engine Model	D1005	C1.1
Frequency	60 Hz	60 Hz
Ducting Length - Continuous Heating	3,354 cfm with 96°F rise over ambient @125 ft	3,354 cfm with 96°F rise over ambient @125 ft
Sound Level @ 23ft (FULL LOAD) dBA	67.1 dBA	65.7 dBA
Sound Level @ 23ft (NO LOAD) dBA	62.9 dBA	62.4 dBA
Phase	1-phase	1-phase
Prime Power (kW)*	8	8
BTU per Hour	1,000,000	1,000,000
Heated Air Output Maximum (cfm)	7,060	7,060
Horsepower (@ 1,800 RPM) ****	11.6	13.8
Oil Change Interval (hr)	200	1,000
Engine Tier	Tier 4 Final	Tier 4 Final
<b>Fuel Tank - Single</b>		
Fuel Capacity gal (L)	210 (794.9)	210 (794.9)
Operating Time - 1 Heater @ Full Load (hrs)	67.5	67.8
Operating Time - 2 Heater @ Full Load (hrs)	35.1	34.6
<b>Fuel Tank - Single</b>		
Fuel Capacity gal (L)	210 (794.9)	210 (794.9)
Operating Time - 1 Heater @ Full Load (hrs)	67.5	67.8
Operating Time - 2 Heater @ Full Load (hrs)	35.1	34.6
<b>Fuel Tank - Multi (optional)</b>		
Heater Fuel Tank - 1 Capacity gal (L)	116 (439.1)	116 (439.1)
Heater Fuel Tank - 2 Capacity gal (L)	116 (439.1)	116 (439.1)
Engine Fuel Tank Capacity gal (L)	50 (189.2)	50 (189.2)
Total Fuel Tank Capacity gal (L)	281.6 (1,065.9)	281.6 (1,065.9)
Operating Time - 1 Heater @ Full Load (hrs)	42.1	42.1
Operating Time - 2 Heater @ Full Load (hrs)	42.1	42.1
<b>Weights &amp; Shipping</b>		
Net Dry Weight (lbs) <sup>†</sup>		4,633
Operating Wet Weight NO Fuel (lbs) <sup>†</sup>		4,654
Operating Wet Weight FULL Fuel (lbs) <sup>†</sup>		5,869
Number of Units on 48' Flatbed		4
Number of Units on 53' Flatbed		4

**Width**  
80.2 in (2,038 mm)

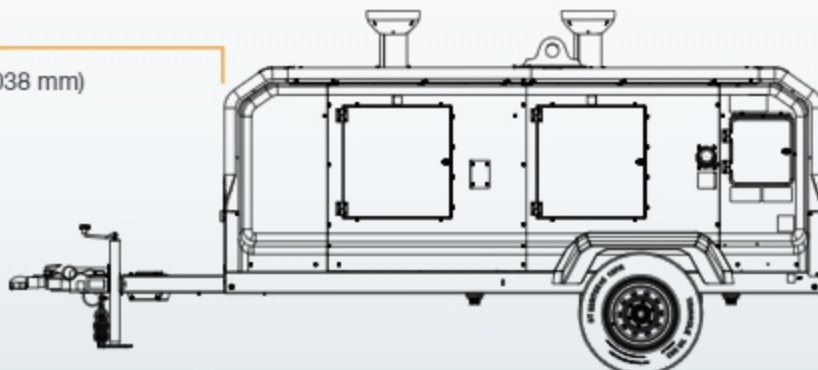

**Length**  
183.4 in (4,657 mm)

**Height**  
Transport Position  
83.9 in (2,130 mm)

## Thermostat Package

- Remote Thermostat
- Lead extension

## 2 5/16" Bulldog Hitch

## Lockable Battery Disconnect

## 12", 16" or 20" Duct Flange Outlets (ducts not included)

## Adjustable Air Recirculation Inlet

## Air Shut off Valve

## Remote Fuel Valve and Pump

## Single Steel Fuel Tank or Multi Poly Fuel Tanks

## Custom Paint

## Telematics (Customer supplied – consult factory)



## COMPROMISE NOTHING.

At Allmand, our sole focus is providing jobsite support equipment to help your customers get the job done. Whenever they need it. Wherever they are. And whatever it takes. What's more, our genuine commitment to you — the highest standard of service and lowest total cost of ownership — is simply unmatched. Choose the equipment that comes with complete confidence that jobsite productivity won't go dark at 2 a.m. **Allmand. Above All.**

**Allmand**

