



Arrangement shown with optional trailer

XQ400 SOUND ATTENUATED

50/60 Hz

FEATURES



EMISSIONS

- EPA Tier 3 and CARB Emissions Certified for non-road mobile applications at all 50 Hz and 60 Hz ratings



CAT® C15 ATAAC DIESEL ENGINE

- Utilizes ACERT™ Technology
- Reliable, rugged, durable design
- Field-proven in multiple applications worldwide
- Four-stroke-cycle diesel engine combines durability with minimum weight while providing dependability and economy
- 50/60 Hz convertibility



CAT® SR4B GENERATOR

- Designed to match performance and output characteristics of Caterpillar diesel engines
- Permanent magnet excitation
- Segregated AC/DC, low voltage accessory box provides single point access to accessory connections



ENCLOSURE

- Made with 12-gauge steel
- Single point lifting eye
- Sound attenuated
- Convenient hand holds and steps for safe operation
- Two coat polyester powder-coated finish

POINTGUARD REMOTE MONITORING SYSTEM

- Utilizes digital and analog inputs for 24/7 alarm monitoring
- Built-in GPS for mapping and driving directions
- Usage reports to allow early adjustment of rental contract
- Fast, easy activation of PointGuard services

ENVIRONMENTALLY FRIENDLY DESIGN

- Sound attenuated for low noise operation
- OSHA compliant safe design
- 110% spill containment for coolant and oil
- UL 142 certified dual wall fuel tank

MULTI-VOLTAGE DISTRIBUTION PANEL

- Dual voltage, manual changeover board
- Load door safety switch
- Rust-free hinges on rear opening door
- Adequate space for line and plug connection without interference
- Remote start and stop contacts
- Remote monitoring hardware

SINGLE-SOURCE SUPPLIER

- Complete systems designed at Caterpillar ISO 9001:2000 certified facilities
- **Certified Prototype Tested** with torsional analysis

WORLDWIDE PRODUCT SUPPORT

- Worldwide parts availability through the Caterpillar dealer network
- With over 1,875 dealer outlets operating in 200 countries, you're never far from the Caterpillar part you need.
- 99.7% of parts orders filled within 48 hours. The best product support record in the industry.
- Caterpillar dealer service technicians are trained to service every aspect of your electric power generation system.

FACTORY INSTALLED STANDARD AND OPTIONAL EQUIPMENT

STANDARD FEATURES	
Air Inlet System	Air cleaner, dual element Turbocharger
Charging System	Battery charger Heavy duty charging alternator
Control Panel	Generator controls and monitoring Fuel tank monitoring Engine controls and monitoring Digital displays Remote monitoring hardware
Cooling System	Fan and belt guards Base mounted radiator Air to air aftercooling
Distribution Panel	Lockable doors Load door safety switch (trips breaker upon door opening) Individual bus bar connections Circuit breaker with 24 VDC shunt trip Remote start/stop contacts Shore power connections
Enclosure	Sound attenuated 12-gauge steel Lockable doors Separate vented battery compartment Single point lifting Exterior oil and water drains with interior valves Hidden exterior fuel drain Hand holds and steps Powder-coated finish
Fuel System	Primary fuel filter/water separator UL 142 dual wall fuel tank, 1970 L (520 g) Radiator-mounted fuel cooler
Generator	Brushless, permanent magnet Coastal corrosion protection Shock mounted VR6 voltage regulator Space heater UL approved Reconnectable 240-480 volt
Mounting System	Generator soft mounted to base Base contains integral fuel tank Skiddable structural steel design 110% oil and coolant spill containment
Remote Monitoring System	PointGuard Model 150G GSM/GPRS digital cellular wireless communications Factory equipped for Rental Management Services: <ul style="list-style-type: none"> • 24/7 alarm monitoring • GPS mapping and directions • Automatic usage reports
Starting System	Electric starting motor Battery set with disconnect switch Jacket water heater with thermostat, shut-off valves

OPTIONAL FEATURES	
Trailer	Full frame support Tandem axle trailer frame with tongue Electric actuated hydraulic brakes with rechargeable battery backup breakaway system Overcenter mechanical parking brake Full length fenders Non-skid surface on steps Heavy duty safety chains and grab hooks Reinforced 4540 kg (10,000 lb) top wind drop jack

SPECIFICATIONS



CAT SR4B GENERATOR

Frame size	450
Type	Permanent magnet brushless
Construction	Single bearing, close coupled
Three phase	12 lead reconnectable
Insulation	Class H with coastal insulation protection
IP rating	22
Alignment	Pilot shaft
Voltage regulator	3-phase sensing with Volts-per-Hertz
Voltage regulation	$\pm \frac{1}{2}\%$ steady state/ $\pm \frac{1}{2}\%$ no load to full load
TIF	Less than 50
THD	Less than 4%



CAT ENGINE

C15 ATAAC, 4-stroke-cycle watercooled diesel	
Bore – mm (in)	137.2 (5.4)
Stroke – mm (in)	171.45 (6.75)
Displacement – L (cu in)	15.2 (928)
Compression ratio	16.1:1
Aspiration	Turbocharged-ATAAC
Engine control	ADEM™ A4



CAT CONTROL PANEL – EMCP 3.2

24 Volt DC Control
NEMA 1, IP22 enclosure
Lockable hinged door
Enclosure mounted
Single location customer connector point
16 light alarm module with alarm horn
Electric fuel level gauge

Consult your Caterpillar dealer for available voltages.



TECHNICAL DATA

		XQ400			
Power Rating		Standby	TMI Ref.	Prime	TMI Ref.
60 Hz	ekW	400	DM9100	365	DM9117
50 Hz	kVA	400	DM9101	365	DM9118
Engine and Container Information					
Engine model		C15			
Container dimensions		see chart on page 6			
Shipping Weight (Dry)					
Unit with trailer	kg (lb)	7952 (17,530)			
Unit without trailer	kg (lb)	6546 (14,430)			
Maximum Fuel Capacity Weight					
Unit with trailer	kg (lb)	9662 (21,300)			
Unit without trailer	kg (lb)	8256 (18,200)			
Engine Lubricating Oil Capacity		L (qts)			
Engine Coolant Capacity with Radiator		L (gal)			
Fuel Tank Capacity		L (gal)			
Fuel Consumption		120.8 (31.9)		112.5 (29.7)	
Fuel Consumption (75% Prime)		L/hr (gal/hr)		94.0 (24.8)	
Running Time @ 75% Prime		hours			
Sound Level					
Standby		dB(A)			
No load @ 7 m (23 ft)		dB(A)			
Prime		dB(A)			
Ambient Capability		Deg C (Deg F)		43 (109.4)	

RATING DEFINITIONS AND CONDITIONS

Meets or Exceeds International Specifications:

- NEMA MG1-32, IEC 60034, CSA, 98/37/EEC, 72/23/EEC, UL 508, UL142, ISO3046/1, ISO8528, 89/336/EEC

Standby – Output available with varying load for the duration of the interruption of the normal source power. Standby power in accordance with ISO8528. Fuel stop power in accordance with ISO3046/1, AS2789, DIN6271, and BS5514.

Prime – Output available with varying load for an unlimited time. Prime power in accordance with ISO8528. 10% overload power in accordance with ISO3046/1, AS2789, DIN6271, and BS5514 available on request.

Ratings are based on SAE J1349 standard conditions.

These ratings also apply at ISO3046/1, DIN6271, and BS5514 standard conditions.

Fuel rates are based on fuel oil of 35° API [@ 16° C (60° F)] gravity having an LHV of 42 780 kJ/kg (18,390 Btu/lb) when used at 29° C (85° F) and weighing 838.9 g/liter (7.001 lb/U.S. gal).

Additional ratings may be available for specific customer requirements. Consult your Caterpillar representative for details.

DISTRIBUTION PANEL

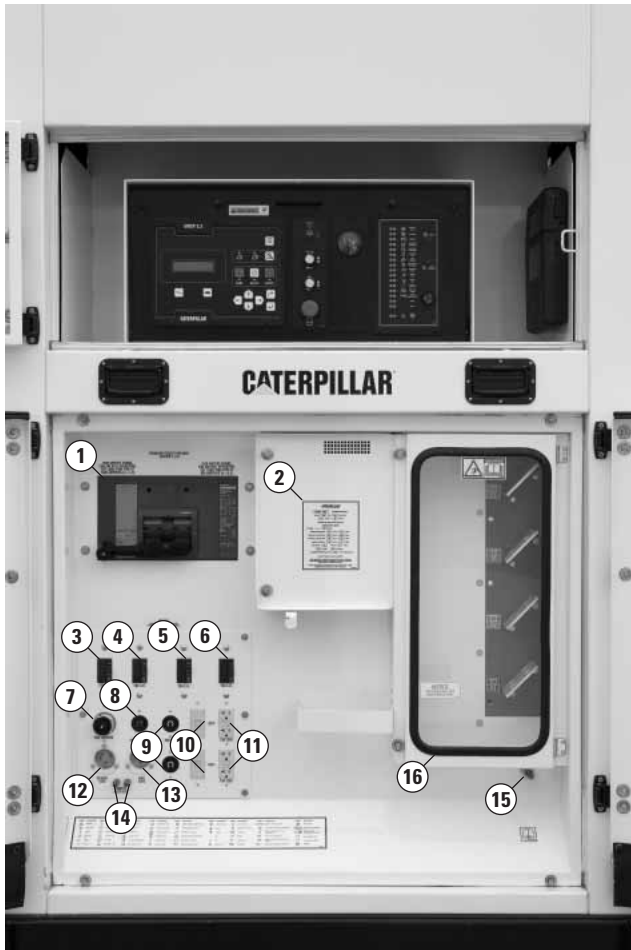

Wiring Descriptions

1. 1600A main breaker 240V/480V with adjustable trip and 24V DC shunt trip
2. Voltage change over board
3. 50 amp 240V branch breaker
4. 20 amp 240V branch breaker
5. 20 amp 120V branch breaker
6. 15 amp 120V branch breaker
7. 50 amp 240V twistlock receptacle
8. 20 amp 240V twistlock receptacle
9. 20 amp 120V twistlock receptacle (2x)
10. 20 amp 120V ground fault interrupter, (2x)
11. 15 amp 120V ground fault interrupter, duplex receptacle (2x)
12. 30 amp 120V battery charger/generator space heater receptacle
13. 30 amp 120V JWH receptacle
14. Remote start/stop contacts
15. 12.7 mm (1/2") ground stud
16. Load connection bus board [6.35 mm × 101.6 mm × 101.6 mm (1/4" × 4" × 4") bus bars]

CONTAINER DIMENSIONS — TOP VIEW

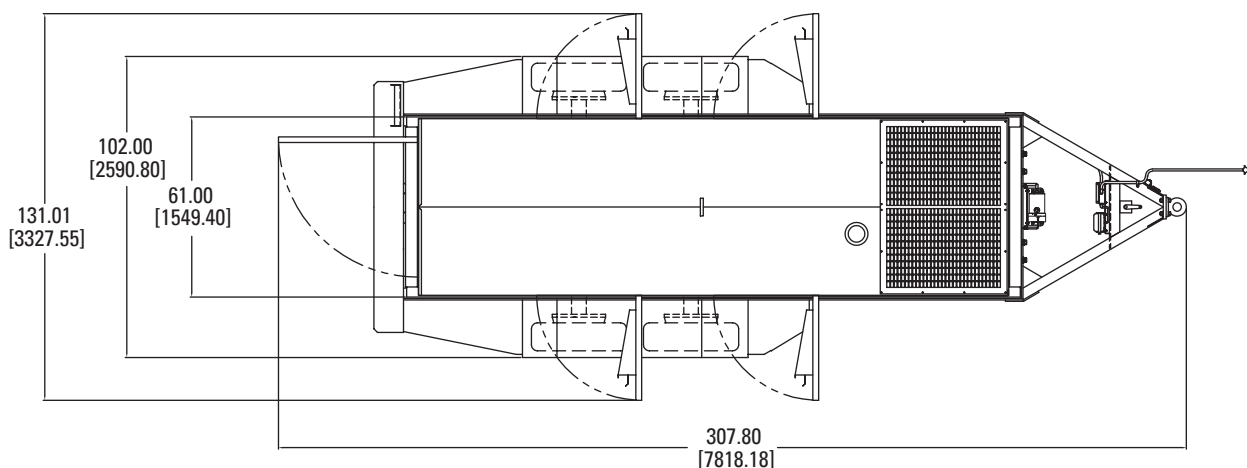

CONTAINER DIMENSIONS — RIGHT SIDE VIEW

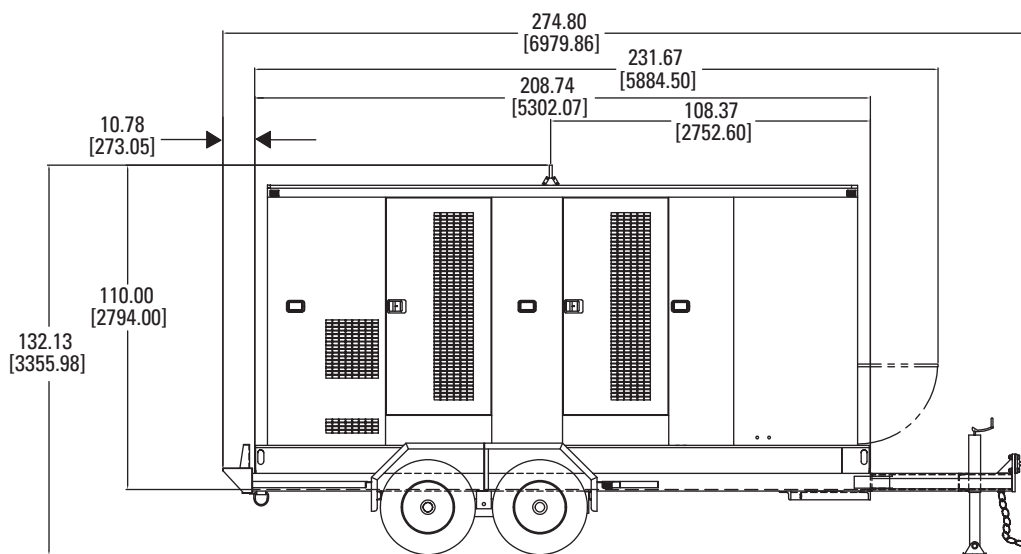

Overall Dimensions				
	Package		With Trailer	
Length	5302.07 mm	208.74 in	6979.8 mm	274.8 in
Width	1549.4 mm	61.0 in	2590.8 mm	102.0 in
Height	2794.0 mm	110.0 in	3355.98 mm	132.13 in

This page intentionally left blank.

This page intentionally left blank.